



State of New Mexico  
General Services Department

Price Agreement

**Awarded Vendor**  
2 Vendors Awarded – See page 6

Price Agreement Number: 00-80500-20-16792

Payment Terms: Net 30

F.O.B.: As Requested

Delivery: See Page 6

**Ship To:**  
New Mexico Department of Transportation  
Various Locations

Procurement Specialist: Kimberly A Hunt-Brown

Telephone No.: (505) 827-0474

Email: kimberly.hunt-brown@state.nm.us

**Invoice:**  
New Mexico Department of Transportation  
As Requested At Time of Order.

For questions regarding this contract please contact:  
James Ortega (505) 629-8884

Title: Slope and Erosion Protection – Gabion Baskets – District 1

Term: June 5, 2020 through June 4, 2021

This Price Agreement is made subject to the “Terms and Conditions” as indicated on subsequent pages.

Accepted for the State of New Mexico

  
Mark Hayden, New Mexico State Purchasing Agent

Date: 06/10/2020

State of New Mexico  
General Services Department  
Purchasing Division  
Price Agreement #: 00-80500-20-16792

Page-2

**Terms and Conditions**  
(Unless otherwise specified)

1. **General:** When the State Purchasing Agent or his/her designee issues a purchase document in response to the bid, a binding contract is created.
2. **Variation in Quantity:** No variation in the quantity of any item called for by this order will be accepted unless such variation has been caused by conditions of loading, shipping, packing or allowances in manufacturing process and then only to the extent, if any, specified in this order.
3. **Assignment:**
  - a. Neither the order, nor any interest therein, nor any claim thereunder, shall be assigned or transferred by the Contractor, except as set forth in Subparagraph 3b or as expressly authorized in writing by the State Purchasing Agent or his/her designee. No such assignment or transfer shall relieve the Contractor from the obligations and liabilities under this order.
  - b. Contractor agrees that any and all claims for overcharge resulting from antitrust violations which are borne by the State as to goods, services, and materials purchased in connection with this bid are hereby assigned to the State.
4. **State Furnished Property:** State furnished property shall be returned to the State upon request in the same condition as received except for ordinary wear, tear and modifications ordered hereunder.
5. **Discounts:** Prompt payment discounts will not be considered in computing the low bid.
6. **Inspection:** Final inspection and acceptance will be made at the destination. Supplies rejected at the destination for nonconformance with specifications shall be removed at the Contractor's risk and expense, promptly after notice of rejection.
7. **Inspection of Plant:** The State Purchasing Agent or his/her designee may inspect, at any reasonable time, the part of the Contractor's, or any subcontractor's plant or place of business, which is related to the performance of this contract.
8. **Commercial Warranty:** The Contractor agrees that the supplies or services furnished under this order shall be covered by the most favorable commercial warranties the Contractor gives for such to any customer for such supplies or services. The rights and remedies provided herein shall extend to the State and are in addition to and do not limit any rights afforded to the State by any other clause of this order. **Contractor agrees not to disclaim warranties of fitness for a particular purpose of merchantability.**
9. **Taxes:** The unit price shall exclude all state taxes.
10. **Packing, Shipping and Invoicing:**
  - a. The State's purchasing document number and the Contractor's name, user's name and location shall be shown on each packing and delivery ticket, package, bill of lading and other correspondence in connection with the shipments. The user's count will be accepted by the Contractor as final and conclusive on all shipments not accompanied by a packing ticket.
  - b. The Contractor's invoice shall be submitted duly certified and shall contain the following information: order number, description of supplies or services, quantities, unit price and extended totals. Separate invoices shall be rendered for each and every complete shipment.
  - c. Invoices must be submitted to the using agency and NOT the State Purchasing Agent.
11. **Default:** The State reserves the right to cancel all or any part of this order without cost to the State, if the Contractor fails to meet the provisions of this order and, except as otherwise provided herein, to hold the Contractor liable for any excess cost occasioned by the State due to the Contractor's default. The Contractor shall not be liable for any excess costs if failure to perform the order arises out of causes beyond the control and without the fault or negligence of the Contractor, such causes include but are not restricted to, acts of God or the public enemy, acts of the State or Federal Government, fires, floods, epidemics, quarantine restrictions, strikes, freight embargoes, unusually severe weather and defaults of

State of New Mexico  
General Services Department  
Purchasing Division  
Price Agreement #: 00-80500-20-16792

Page-3

subcontractors due to any of the above, unless the State shall determine that the supplies or services to be furnished by the subcontractor were obtainable from other sources in sufficient time to permit the Contractor to meet the required delivery scheduled. The rights of the State provided in this paragraph shall not be exclusive and are in addition to any other rights now being provided by law or under this order.

**12. Non-Collusion:** In signing this bid the Contractor certifies he/she has not, either directly or indirectly, entered into action in restraint of free competitive bidding in connection with this offer submitted to the State Purchasing Agent or his/her designee.

**13. Nondiscrimination:** Contractor doing business with the State of New Mexico must be in compliance with the Federal Civil Rights Act of 1964 and Title VII of the Act (Rev. 1979) and the Americans with Disabilities Act of 1990 (Public Law 101-336).

**14. The Procurement Code:** Sections 13-1-28 through 13-1-199 NMSA 1978, imposes civil and criminal penalties for its violation. In addition the New Mexico criminal statutes impose felony penalties for bribes, gratuities and kickbacks.

**15. Items:** All bid items are to be NEW and of most current production, unless otherwise specified.

**16. Payment for Purchases:** Except as otherwise agreed to: late payment charges may be assessed against the user state agency in the amount and under the conditions set forth in Section 13-1-158 NMSA 1978.

**17. Workers' Compensation:** The Contractor agrees to comply with state laws and rules pertaining to Workers' Compensation benefits for its employees. If the Contractor fails to comply with Workers' Compensation Act and applicable rules when required to do so, this Agreement may be terminated by the contracting agency.

**18. Submission of Bid:** Bids must be submitted in a sealed envelope with the bid number and opening date clearly indicated on the bottom left hand side of the front of the envelope. Failure to label bid envelope will necessitate the premature opening of the bid in order to identify the bid number.

**19. Contractor Personnel:** Personnel proposed in the Contractor's written bid to the Procuring Agency are considered material to any work performed under this Price Agreement. Once a Purchase Order or contract has been executed, no changes of personnel will be made by the Contractor without prior written consent of the Procuring Agency. Replacement of any Contractor personnel, if approved, shall be with personnel of equal ability, experience, and qualifications. The Contractor will be responsible for any expenses incurred in familiarizing the replacement personnel to insure their being productive to the project immediately upon receiving assignments. Approval of replacement personnel shall not be unreasonably withheld. The Procuring Agency shall retain the right to request the removal of any of the Contractor's personnel at any time.

**20. Subcontracting:** The Contractor shall not subcontract any portion of the Price Agreement without the prior written approval of the Procuring Agency. No such subcontracting shall relieve the Contractor from its obligations and liabilities under this Price Agreement, nor shall any subcontracting obligate payment from the Agency.

**21. Records and Audit:** The Contractor shall maintain detailed time and expenditure records that indicate the date, time, nature, and cost of services rendered during this Price Agreement's term and effect, and retain them for a period of three (3) years from the date of final payment under this Price Agreement. The records shall be subject to inspection by the Agency, State Purchasing Division, Department of Finance and Administration, and for Information Technology contracts, State Chief Information Officer. The Agency shall have the right to audit billings, both before and after payment. Payment for services under this Price Agreement shall not foreclose the right of the Agency to recover excessive or illegal payments.

**22. Subcontracts:** The foregoing requirements for Contractor Personnel, Subcontracting, and Audit shall be inserted into all subcontracts from the prime contractor to the subcontractor.

### **New Mexico Employees Health Coverage**

A. If Contractor has, or grows to, six (6) or more employees who work, or who are expected to work, an average of at least 20 hours per week over a six (6) month period during the term of the contract, Contractor certifies, by signing this agreement, to have in place, and agrees to maintain for the term of the contract, health insurance for its New Mexico Employees and offer that health insurance to its New Mexico Employees if the expected annual value in the aggregate of any and all contracts between Contractor and the State exceeds \$250,000 dollars.

B. Contractor agrees to maintain a record of the number of its New Mexico Employees who have (a) accepted health insurance; (b) declined health insurance due to other health insurance coverage already in place; or (c) declined health insurance for other reasons. These records are subject to review and audit by a representative of the state.

C. Contractor agrees to advise all of its New Mexico Employees of the availability of State publicly financed health care coverage programs by providing each of its New Mexico Employees with, as a minimum, the following web site link to additional information: <https://www.insurenemexico.state.nm.us/>.

D. For purposes of this Paragraph, the following terms have the following meanings:

(1) "New Mexico Employee" means any resident of the State of New Mexico employed by Contractor who performs the majority of the employee's work for Contractor within the State of New Mexico, regardless of the location of Contractor's office or offices; and

(2) "offer" means to make available, without unreasonable restriction, enrollment in one or more health coverage plans and to actively seek and encourage participation in order to achieve the goals of Executive Order 2007-049. This could include State publicly financed public health coverage programs such as *Insure New Mexico!*

### **Department Price Agreement**

#### **Article I – Statement of Work**

Under the terms and conditions of this Price Agreement, the using agency may issue orders for items and/or services described herein.

The terms and conditions of this Price Agreement shall form a part of each order issued hereunder.

The items and/or services to be ordered shall be listed under Article IX – Price Schedule. All orders issued hereunder will bear both an order number and this Price Agreement number. It is understood that no guarantee or warranty is made or implied by either the New Mexico State Purchasing Agent or the user that any order for any definite quantity will be issued under this Price Agreement. The Contractor is required to accept the order and furnish the items and/or services in accordance with the articles contained hereunder for the quantity of each order issued.

#### **Article II –Term**

The term of this Price Agreement for issuance of orders shall be as indicated in specifications.

#### **Article III –Specifications**

Items and/or services furnished hereunder shall conform to the requirements of specifications and/or drawings applicable to items listed under Article IX - Price Schedule. Orders issued against this schedule will show the applicable price agreement item(s), number(s), and price(s); however they may not describe the item(s) fully.

#### **Article IV – Shipping and Billing Instructions**

Contractor shall ship in accordance with the instructions of this form. Shipment shall be made only against specific orders

State of New Mexico  
General Services Department  
Purchasing Division  
Price Agreement #: 00-80500-20-16792

Page-5

which the user may place with the contractor during the term indicated in Article II – Term. The Contractor shall enclose a packing list with each shipment listing the order number, price agreement number and the commercial parts number (if any) for each item. Delivery shall be made as indicated on page 1. If Contractor is unable to meet stated delivery the State Purchasing Agent must be notified.

**Article V – Termination**

The Agency may terminate this Agreement for convenience or cause. The Contractor may only terminate this Agreement based upon the Agency's uncured, material breach of this Agreement. Contractor shall give Agency written notice of termination at least thirty (30) days prior to the intended date of termination, which notice shall (i) identify all the Agency's material breaches of this Agreement upon which the termination is based and (ii) state what the Agency must do to cure such material breaches. Contractor's notice of termination shall only be effective (i) if the Agency does not cure all material breaches within the thirty (30) day notice period or (ii) in the case of material breaches that cannot be cured within thirty (30) days, the Agency does not, within the thirty (30) day notice period, notify the Contractor of its intent to cure and begin with due diligence to cure the material breach. Termination of this Contract, however, shall not affect any outstanding orders. This provision is not exclusive and shall not waive other rights and remedies afforded either party in the event of breach of contract or default. In such instances the contract may be cancelled effective immediately.

**Article VI – Amendment**

This Price Agreement may be amended by mutual agreement of the New Mexico State Purchasing Agent or his/her designee and the Contractor upon written notice by either party to the other. An amendment to this Price Agreement shall not affect any outstanding orders issued prior to the effective date of the amendment as mutually agreed upon, and as published by the New Mexico State Purchasing Agent or his/her designee. Amendments affecting price adjustments and/or the extension of a price agreement expiration date are not allowed unless specifically provided for in the bid and price agreement specifications.

**Article VII – Issuance of Orders**

Only written signed orders are valid under this Price Agreement.

**Article VIII – Packing (if applicable)**

Packing shall be in conformance with standard commercial practices.

**Article IX – Price Schedule**

Prices as listed in the price schedule hereto attached are firm.

State of New Mexico  
General Services Department  
Purchasing Division  
Price Agreement #: 00-80500-20-16792

Page-6

**Awarded Vendors**

**(AA) 0000043793**

Kimo Constructors  
3681 Highway 47  
Bosque Farms, NM 87068  
Email: [lucas@kimonm.com](mailto:lucas@kimonm.com)  
Telephone No.: (505) 869-8311

Delivery: 2912 E. Pine St., Deming, NM 88030  
OR as requested

**(AB) 000007745**

Maccaferri Inc.  
10303 Governor Lane Boulevard  
Williamsport, MD 21795  
Email: [j.schweighofer@maccaferri.com](mailto:j.schweighofer@maccaferri.com); [m.worthen@maccaferri.com](mailto:m.worthen@maccaferri.com)  
Telephone No.: (505) 344-7737

Delivery: as requested

State of New Mexico  
General Services Department  
Purchasing Division  
Price Agreement #: 00-80500-20-16792

Page-7

**Specifications:**

The New Mexico Department of Transportation (NMDOT) wishes to establish a Price Agreement for Slope and Erosion Protection Structures (Gabion Baskets) for NMDOT District 1.

**Minimum Requirements:**

All Gabions shall be in accordance with Section 602, New Mexico Department of Transportation Standard Specifications for Highway and Bridge Construction, 2019 or latest Edition ([https://dot.state.nm.us/content/dam/nmdot/Plans\\_Specs\\_Estimates/2019\\_Specs.pdf](https://dot.state.nm.us/content/dam/nmdot/Plans_Specs_Estimates/2019_Specs.pdf)).

All work performed under this contract shall meet the specifications as set forth in this price agreement, and all applicable New Mexico State Department of Transportation Standard Specifications for Highway and Bridge Construction, special provisions, standard drawings and supplemental specifications (current edition). They are available on the NMDOT website, at the following link: <http://dot.state.nm.us/content/nmdot/en/Standards.html> and they are available for purchase at the General Office Financial Control Section (505) 469-4983.

Gabions shall be supplied folded flat to facilitate handling and transporting.

Prior to payment, vendor shall supply Certificates of Compliance to NMDOT District 1 Maintenance Assistant District Engineer or Designee.

All material shall be subject to inspection for acceptance by authorized NMDOT personnel.

**Term:**

The term of this Price Agreement shall be for one (1) year from date of award with the option to extend for a period of three (3) additional years, on a year-to-year basis, by mutual agreement of all parties and approval of the New Mexico State Purchasing Agent at the same price, terms and conditions. This Price Agreement shall not exceed four (4) years.

**Tax Note:**

Bid shall not include state gross receipts tax (GRT) or local option tax(es). Such tax or taxes shall be added at time of invoicing at current rate, and shown as a separate item to be paid by user.

The GRT rate shall be calculated based on the delivery location.

**Vendors are required to have prior product approval through the NMDOT Product Evaluation Program in order for bid item to be awarded.**

**Bidding Information:**

The conditions and specifications set out in the Invitation to Bid are inseparable and indivisible. Any vendor, by submitting a bid, agrees to be bound by all such conditions and/or specifications. All conditions and specifications in the Invitation to Bid, and all other documents required to be submitted, shall be returned by the vendor in his/her bid package. Failure to do so, or any attempt to vary or change the conditions or specifications of the Invitation to Bid shall, at the discretion of the State, constitute grounds for rejection of the entire bid.

**Method of Award:**

Pursuant to the Procurement Code, Sections 13-1-153 and 13-1-154, the State reserves the right to issue multiple awards to obtain the items listed. Multiple awards are recommended to ensure availability and timely delivery. Awards will be made to meet the best interests of the State of New Mexico.

State of New Mexico  
General Services Department  
Purchasing Division  
Price Agreement #: 00-80500-20-16792

Page-8

This bid may be awarded to the lowest responsible bidder(s). The State Purchasing Division reserves the right to reject any and all bids, to waive technical irregularities, and to award the Price Agreement to the bidder whose bid is deemed to be in the best interest of the State of New Mexico.

**Escalation Clause:**

In the event of a product cost increase, an escalation request will be submitted for review to the NMDOT on an individual basis. This measure is not intended to allow any increase in profit margin, but is solely intended to allow compensation for actual cost increases directly related to bid items.

To facilitate prompt consideration, all requests for price increase must include all information listed below:

1. Price Agreement Item Number
2. Current Item Price
3. Proposed New Price
4. Percentage of Increase
5. Mill/Supplier Notification of price increase indicating percentage of increase including justification for increase.

The NMDOT upon review of an escalation request may require additional supporting documentation prior to providing a written recommendation to the General Services Department's (GSD) State Purchasing Division. Final determination on the approval or disapproval of the escalation request will be made by GSD's State Purchasing Division.

**Hold Harmless Clause:**

Contractor shall indemnify and hold harmless the State, its officers, and employees, against liability, claims, damages, losses, or expenses arising out of bodily injury to persons or damage to properties caused by, or resulting from, Contractor's and/or its employees, own negligent acts or omissions while Contractor, and/or its employees perform or fail to perform its obligations and duties under the terms and conditions of this Price Agreement. This Save Harmless and Indemnification Clause is subject to the immunities, provisions, and limitations of the Tort Claims Act (Section 41-4-1, et seq., NMSA 1978 Comp. and Section 56-7-1 NMSA 1978 Comp.) and any amendments thereto.

It is specifically agreed between the parties executing this Price Agreement that it is not intended by any of the provisions of any part of the Price Agreement to create the public or any member hereof a third party beneficiary or to authorize anyone not a party to the Price Agreement to maintain a suit for wrongful death, bodily and/or personal injury to persons, damage to properties and/or other claims whatsoever pursuant to the provisions of this Price Agreement.

**Payment Provisions:**

Within fifteen (15) days after the date the Department receives written notice from the Contractor that payment is requested for services, construction or items of tangible personal property delivered on site and received, the Department shall issue a written certification of complete or partial acceptance or rejection of the services, construction, or items of tangible personal property. If the Department finds that the services, construction, or items of tangible personal property are not acceptable, it shall, within thirty (30) days after the date of receipt of written notice from the Contractor that payment is requested, provide to the Contractor, a letter of exception explaining the defect or objection to the services, construction, or delivered tangible personal property along with the details of how the Contractor may proceed to provide remedial action.

Upon certification by the Department that the services, construction, or delivered tangible personal property have been received and accepted, payment shall be tendered to the Contractor within thirty (30) days after the date of certification. If payment is made by mail, the payment shall be deemed tendered on the date it is postmarked. After the thirtieth (30<sup>th</sup>) day from the date that written certification of acceptance is issued, late payment charges shall be paid on the unpaid balance due on the contract to the Contractor at the rate of one and one half percent (1-1/2%) per month. For purchases funded by state or federal grants to local public bodies, if the local public body has not received the funds from the federal or state funding agency, but has already certified that the services or items of tangible personal property have been received and accepted, payments shall be tendered to the Contractor within five (5) working days of receipt of funds from that funding agency. Final payment shall be made within



State of New Mexico  
General Services Department  
Purchasing Division  
Price Agreement #: 00-80500-20-16792

Page-9

thirty (30) days after the work has been approved and accepted by the Department's Secretary or his duly authorized representative.

The Contractor agrees to comply with state laws and rules pertaining to Worker's Compensation Insurance coverage for its employees. If Contractor fails to comply with the Worker's Compensation Act and applicable rules when required to do so, the Price Agreement may be cancelled effective immediately.

**State Compensation:**

The prices quoted herein represent the total compensation to be paid by the State for the goods and/or services provided including any and all labor, equipment, fuel, tools, materials, taxes, permits, licenses, or other costs necessary to complete the service and/or provide the goods. The prices quoted in this Invitation to Bid include an amount sufficient to cover such costs. The prices and amounts quoted herein are not a guarantee of work or orders to be placed by the State under this price agreement with the bidder.

State of New Mexico  
 General Services Department  
 Purchasing Division  
 Price Agreement #: 00-80500-20-16792

**Items:**

Item	Approx. Qty.	Unit	Article and Description	Price	
				(AA)	(AB)
001	20	Each	Gabion Type A 8x10 (0.120 In Diameter) Galvanized Mesh 6'x3'x3' Basket	\$64.10	\$55.00
002	50	Each	Gabion Type B 8x10 (0.120 In Diameter) Galvanized Mesh 9'x3'x3' Basket	\$89.75	\$77.00
003	150	Each	Gabion Type C 8x10 (0.120 In Diameter) Galvanized Mesh 12'x3'x3' Basket	\$108.40	\$93.00
004	20	Each	Gabion Type D 8x10 (0.120 In Diameter) Galvanized Mesh 6'x3'x1.5' Basket	\$44.30	\$38.00
005	5	Each	Gabion Type E 8x10 (0.120 In Diameter) Galvanized Mesh 9'x3'x1.5' Basket	\$64.10	\$55.00
006	30	Each	Gabion Type F 8x10 (0.120 In Diameter) Galvanized Mesh 12'x3'x1.5' Basket	\$81.60	\$70.00
007	5	Each	Gabion Type G 8x10 (0.120 In Diameter) Galvanized Mesh 6'x3'x1' Basket	\$38.45	\$33.00
008	5	Each	Gabion Type H 8x10 (0.120 In Diameter) Galvanized Mesh 9'x3'x1' Basket	\$56.55	\$48.50
009	5	Each	Gabion Type I 8x10 (0.120 In Diameter) Galvanized Mesh 12'x3'x1' Basket	\$71.10	\$61.00
010	5	Each	Gabion 8x10 (0.120 In Diameter) Galvanized Mesh 12'x2'x2' Basket	\$71.10	\$61.00
011	5	Each	Gabion Type Si 8x10 (0.120 In Diameter) Galvanized Mesh 4.5'x3'x3' Basket	\$53.60	\$46.00
012	5	Each	Gabion Type Si 8x10 (0.120 In Diameter) Galvanized Mesh 4.5'x3'x6' Basket	\$94.40	\$81.00
013	5	Each	Gabion Type Si 8x10 (0.120 In Diameter) Galvanized Mesh 4.5'x3'x12' Basket	\$162.00	\$139.00
014	5	Each	Reno Mattress Type T 6x8 (0.087 In Diameter) Galvanized Mesh Including Lid 9'x6'x9"	\$75.75	\$65.00
015	5	Each	Reno Mattress 6x8 (0.087 In Diameter) Galvanized Mesh Including Lid 9'x6'x1'	\$96.15	\$82.50
016	5	Each	Reno Mattress Type U 6x8 (0.087 In Diameter) Galvanized Mesh Including Lid 12'x6'x9"	\$97.90	\$84.00
017	5	Each	Reno Mattress Type Z 6x8 (0.087 In Diameter) Galvanized Mesh Including Lid 12'x6'x1'	\$108.40	\$93.00
018	50	Each	Roll 8x10 (0.120 In Diameter) Galvanized Mesh 6'x150' or 100 Square Yards	\$575.75	\$494.00

State of New Mexico  
General Services Department  
Purchasing Division  
Price Agreement #: 00-80500-20-16792

Item	Approx. Qty.	Unit	Article and Description	Price	
				(AA)	(AB)
019	25	Each	Roll 8x10 (0.120 In Diameter) Galvanized Mesh 12'x150' or 200 Square Yards	\$1,047.80	\$899.00
020	2	Each	Mattress Roll 8x10 (0.120 In Diameter) Galvanized Mesh Including Lid 99'x6'x1'	\$1,047.80	\$899.00
021	2	Each	Mattress Roll 8x10 (0.120 In Diameter) Galvanized Mesh Including Lid 99'x9'x1'	\$1,515.15	\$1,300.00
022	2	Each	Mattress Roll 8x10 (0.120 In Diameter) Galvanized Mesh Including Lid 99'x6'x1.5'	\$1,280.90	\$1,099.00
023	2	Each	Mattress Roll 8x10 (0.120 In Diameter) Galvanized Mesh Including Lid 99'x9'x1.5'	\$1,839.15	\$1,578.00
024	5	Each	Galvanized "Spenax" Ring Fasteners (0.118 In Diameter ASTM 975 Section 6.3 Compliant) 17 Pound Box or 1,600 Fasteners Per Box - each Box is a Unit	\$120.05	\$103.00
025	100	Each	L 5'X 4"X4"X3/8" Thick Steel Stakes	\$34.95	\$32.00
026	2	Each	No. 9 Hog Ring Fasteners (ASTM 975 Section 6.3 Compliant) 25 Pound Box Or 2,200 Fasteners Per Box - each Box is a Unit	\$93.25	\$80.00
027	5	Each	No. 9 Tie Wire (0.148 In Diameter) 100 Pound Coils - each Coil is a Unit	\$145.70	\$125.00
028	5	Each	No. 11 Tie Wire (0.120 In Diameter) 100 Pound Coils - each Coil is a Unit	\$137.55	\$118.00
029	5	Each	No. 14 Tie Wire (0.083 In Diameter) 55 Pound Coils - each Coil is a Unit	\$88.60	\$76.00
030	1000	Each	Macties or Approved Equal Preformed Galvanized Stiffeners (11 Gage Or 9 Gage) as an Alternative to Internal Gabion Connecting Wires	\$0.50	\$0.45
031	520	Each	3/4" Diameter X 7" Long Galvanized Expansion Hook Bolt	\$16.80	No bid
032	520	Each	3/4" Diameter X 1'-0" Long Galvanized Hook Bolt	\$18.65	No bid
033	5	Each	Class 1 Or 2 Drainage Geotextile (Mactex H 60.1 - Mx 275 or Approved Equal) 12.5'x360' Roll - each Roll is a Unit	\$466.20	\$400.00
034	5	Each	Class 1 Or 2 Drainage Geotextile (Mactex H 60.1 - Mx 275 or Approved Equal) 15'x300' Roll - each Roll is a Unit	\$466.20	\$400.00
035	5	Each	Geogrid Type I Roll (Macgrid Eg 12.19 Maccaferri or Approved Equal) 12.9'x246' Roll - each Roll is a Unit	\$361.30	\$310.00
036	5	Each	Geogrid Type II Roll (Macgrid Eg 19.29 Maccaferri or Approved Equal) 12.9'x164' Roll - each Roll is a Unit	\$442.90	\$380.00

\*\*\* 36 Items Total \*\*\*

Metal Gabion Basket Stake Drawing:

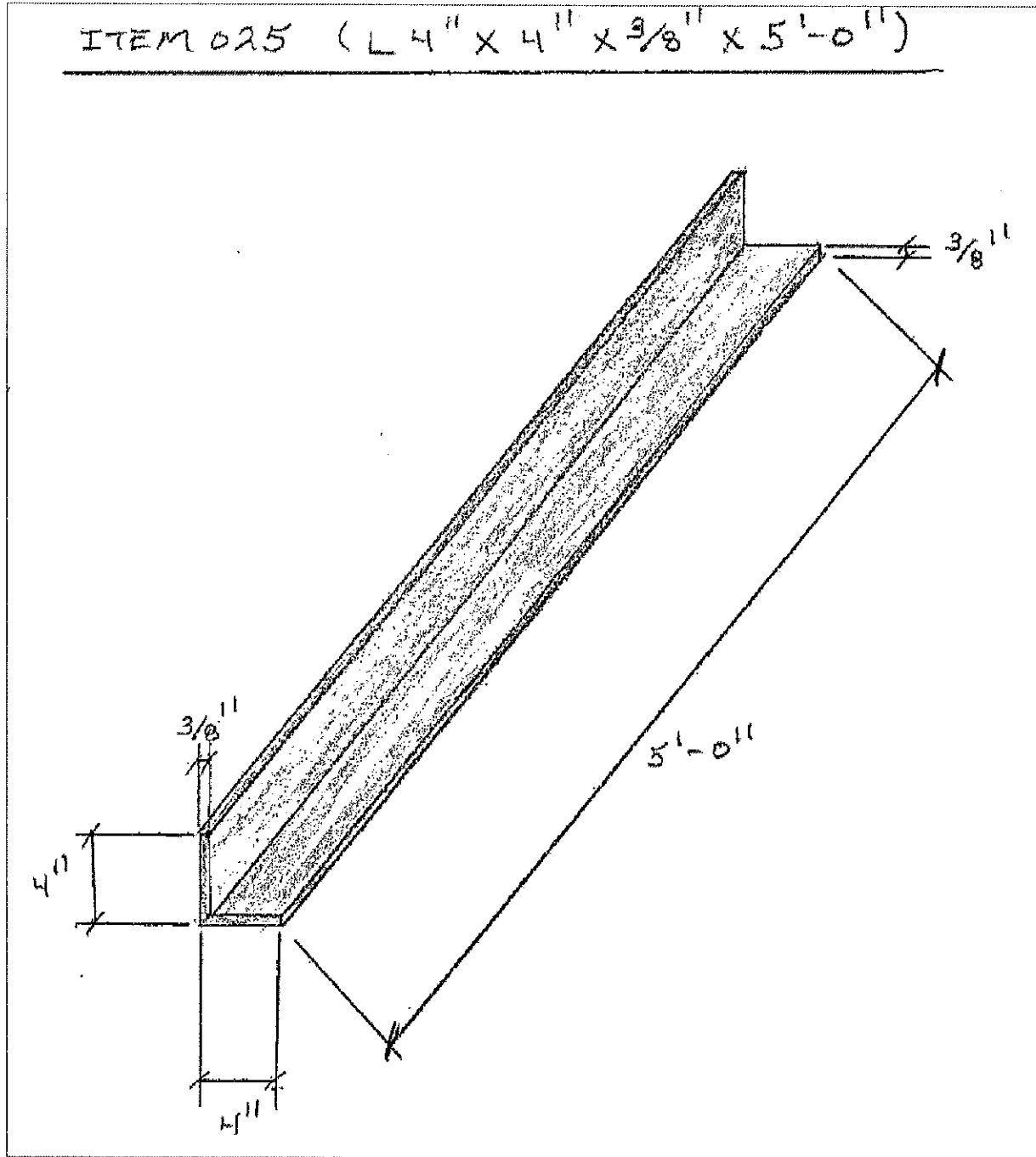

### NEW MEXICO DEPARTMENT OF TRANSPORTATION DISTRICTS

